

Rev. A Major Revision 8.5.14 RN
 Rev. B All openings enlarged slightly 4.17.15 RN
 Rev. C Backside extrusion removed 5.12.15 RN
 Rev. D LED openings enlarged (indicated) 7.23.15 RN
 Rev. E Hole dia. for mount blocks inc. from .096 to .125 11.1.16 RN
 Rev. F Edge slots added 11.7.16 RN
 Rev. G Major revision to edge slots 11.9.16 RN

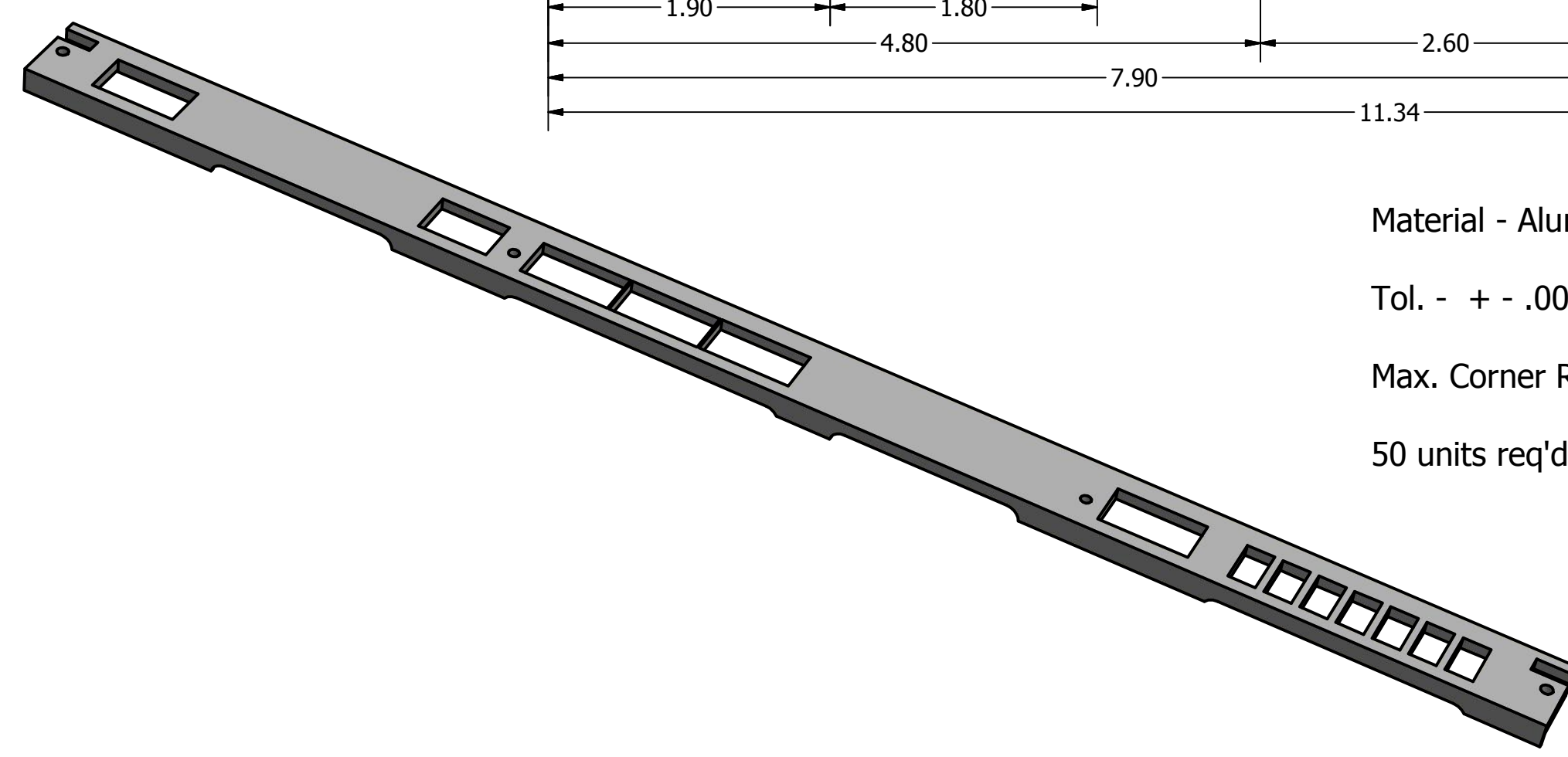
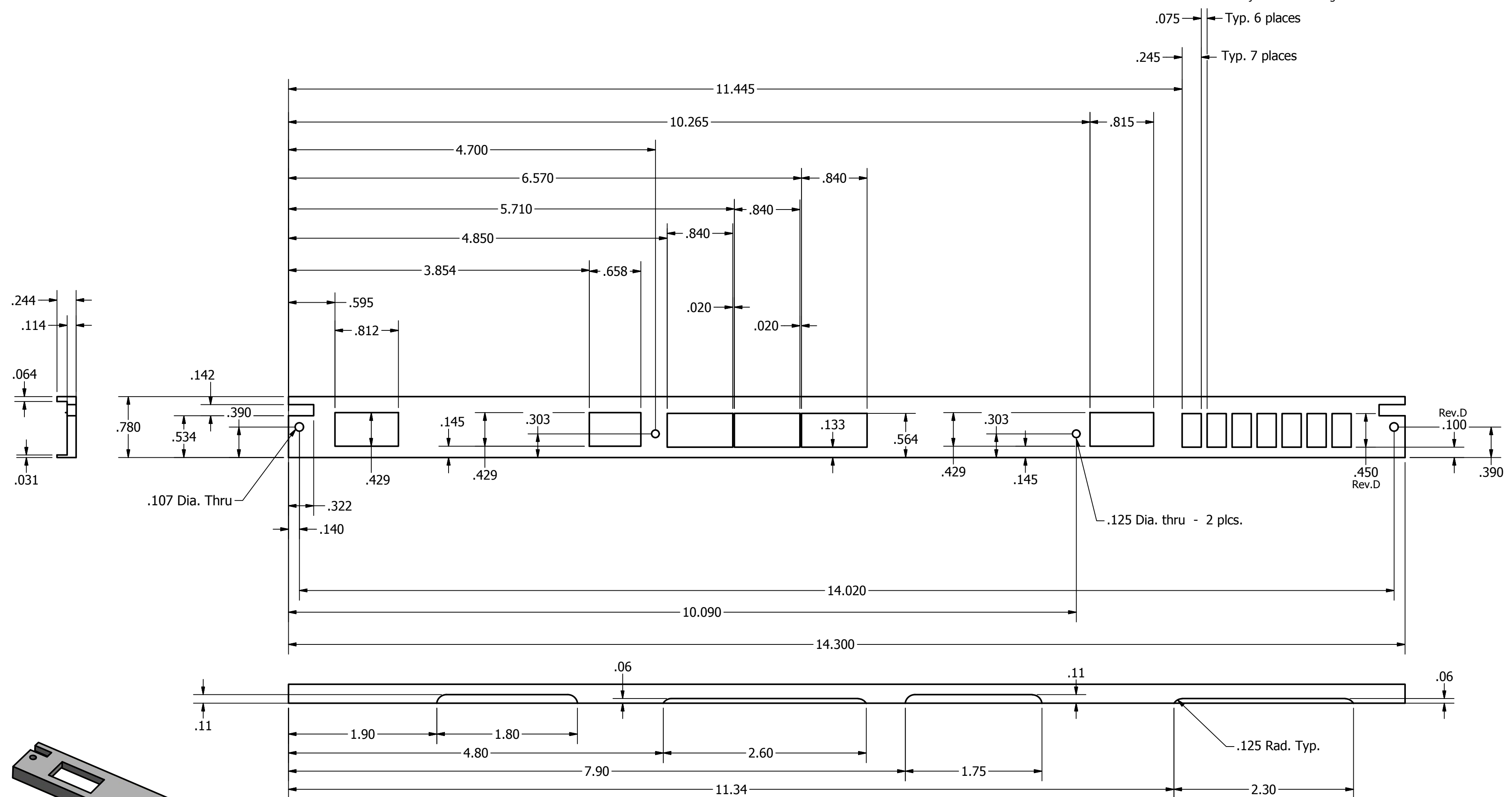

Material - Alum. 6061-T6
 Tol. - + - .005
 Max. Corner Rad. .032
 50 units req'd.

DRAWN rnorthrop	6/16/2014	University of Chicago		
CHECKED M.B.				
QA		F T K Front Panel Detail		
MFG				
APPROVED		SIZE C	DWG NO AtlasFrontPanelRevG	REV G
		SCALE	SHEET 1 OF 1	