

**Sheet 9-1
Power 24A**

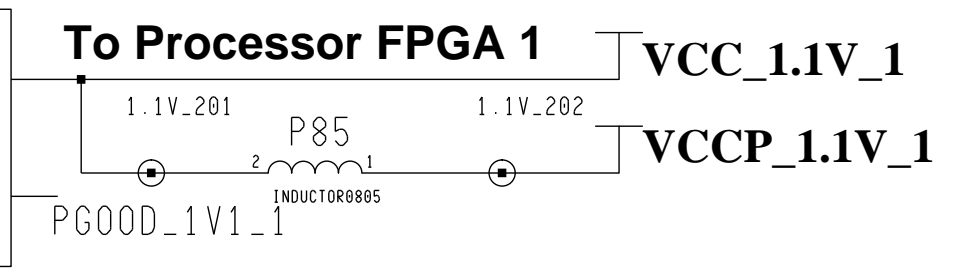

**Sheet 9-3
Power 24A**

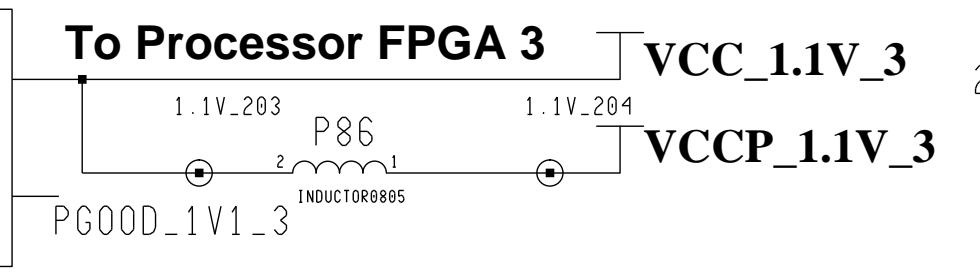

**Sheet 9-2
Power 24A**

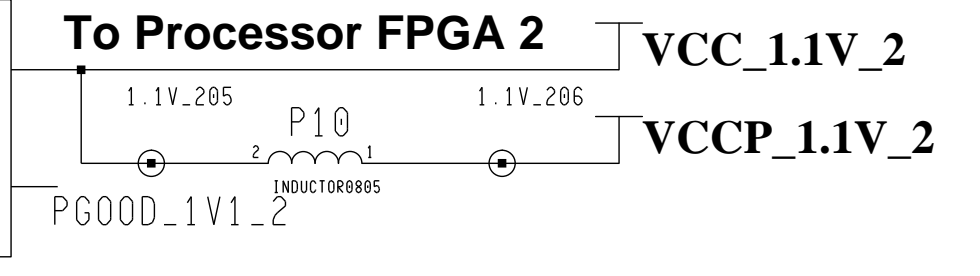

**Sheet 9-4
Power 24A**

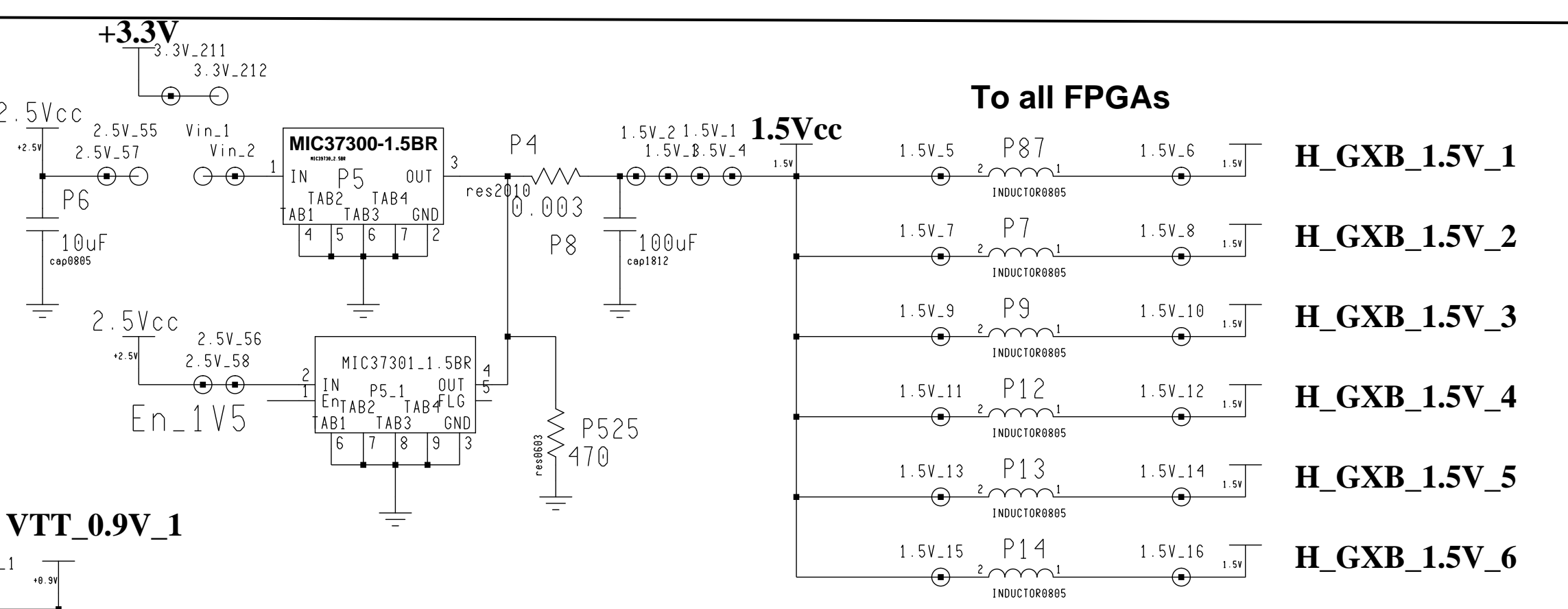
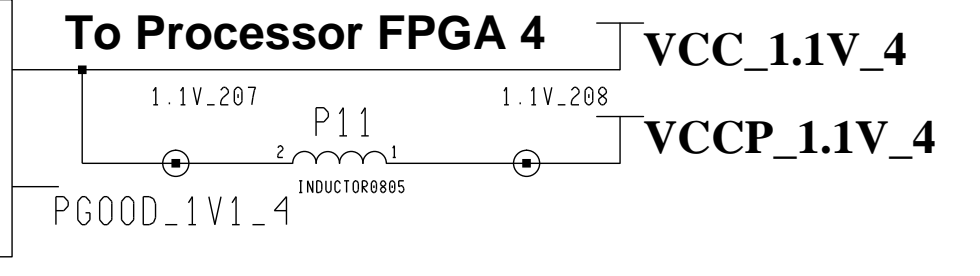

**Sheet 10-1
Power 2x12A**

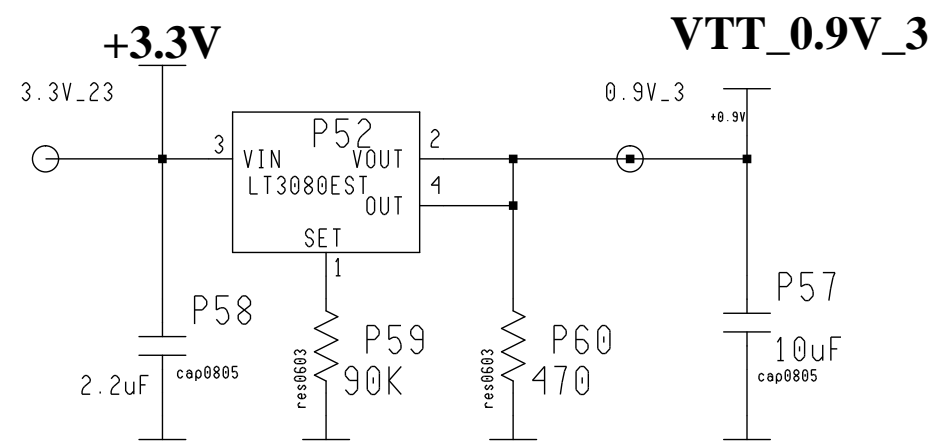
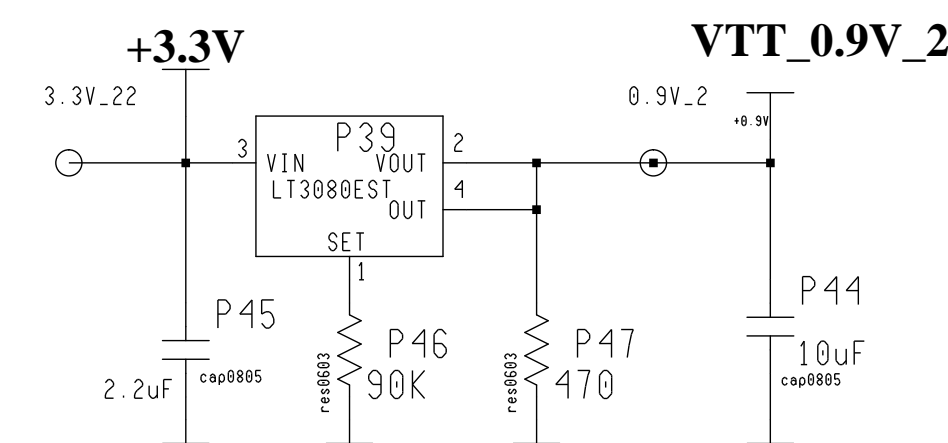
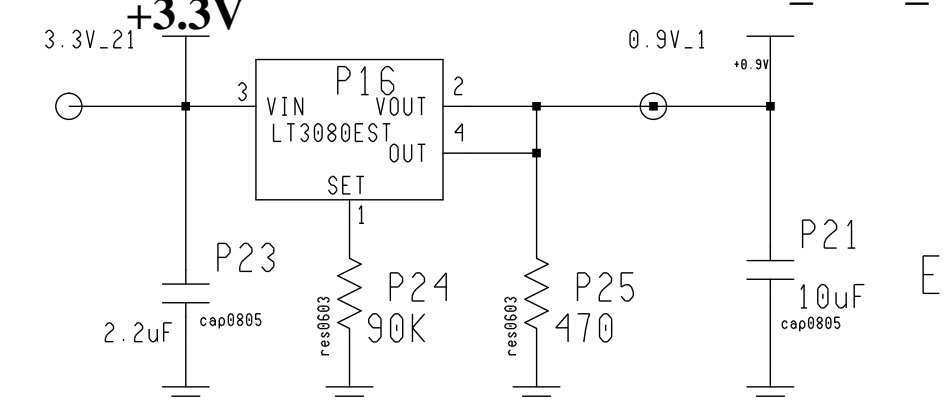
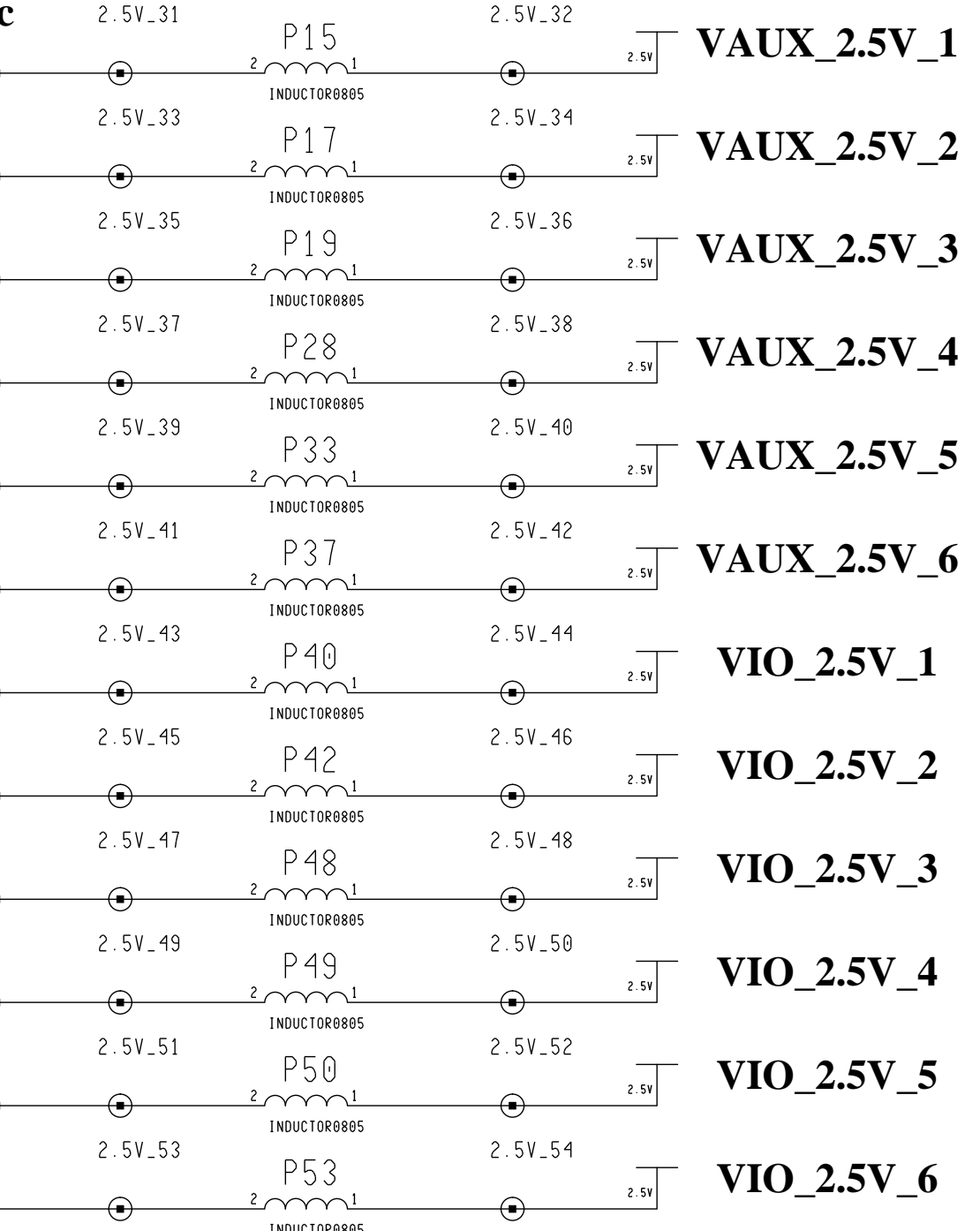
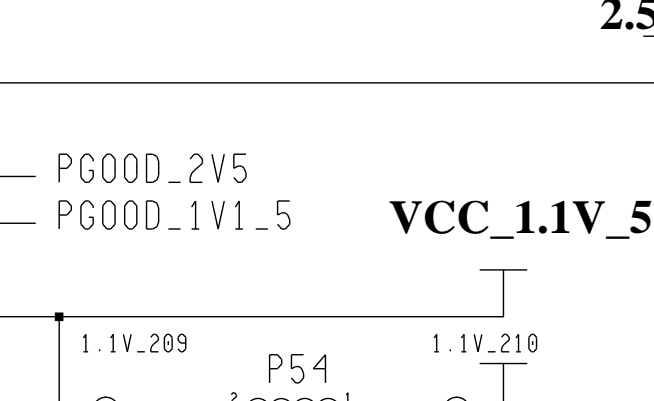

**Sheet 11
Power 1x12A**

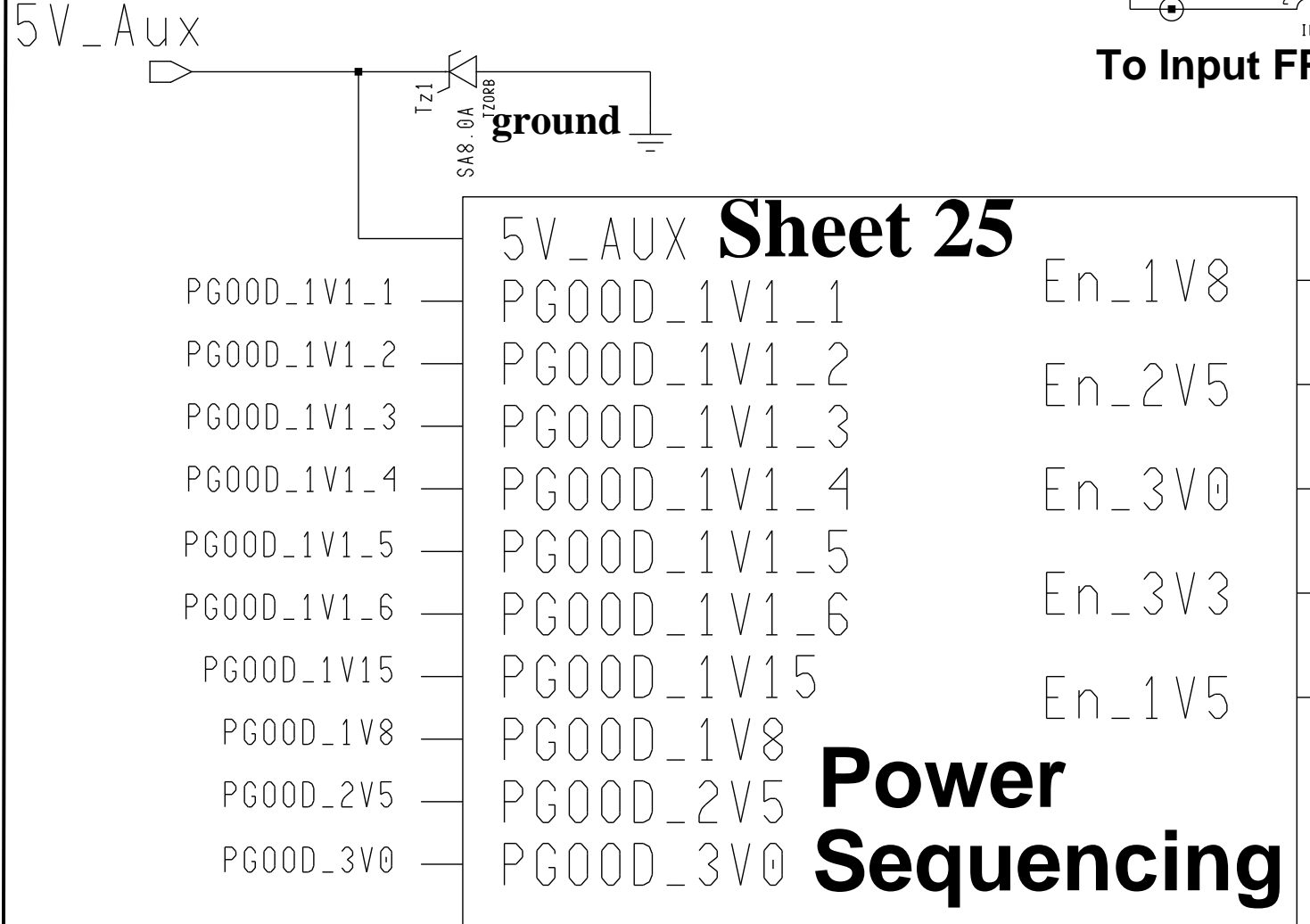
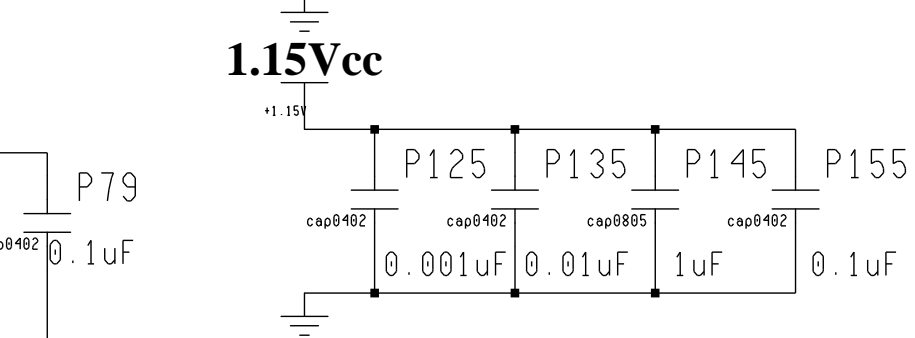
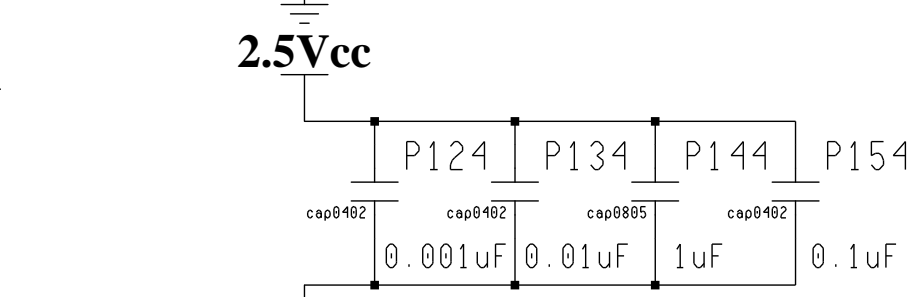
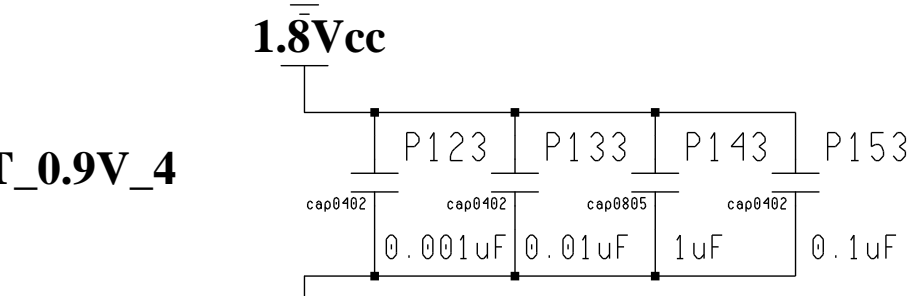
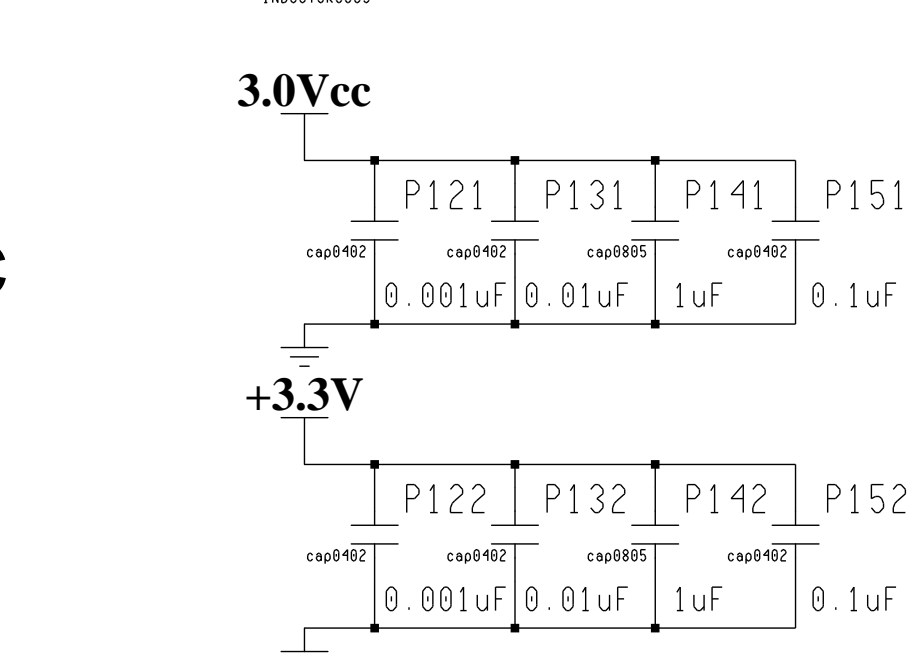
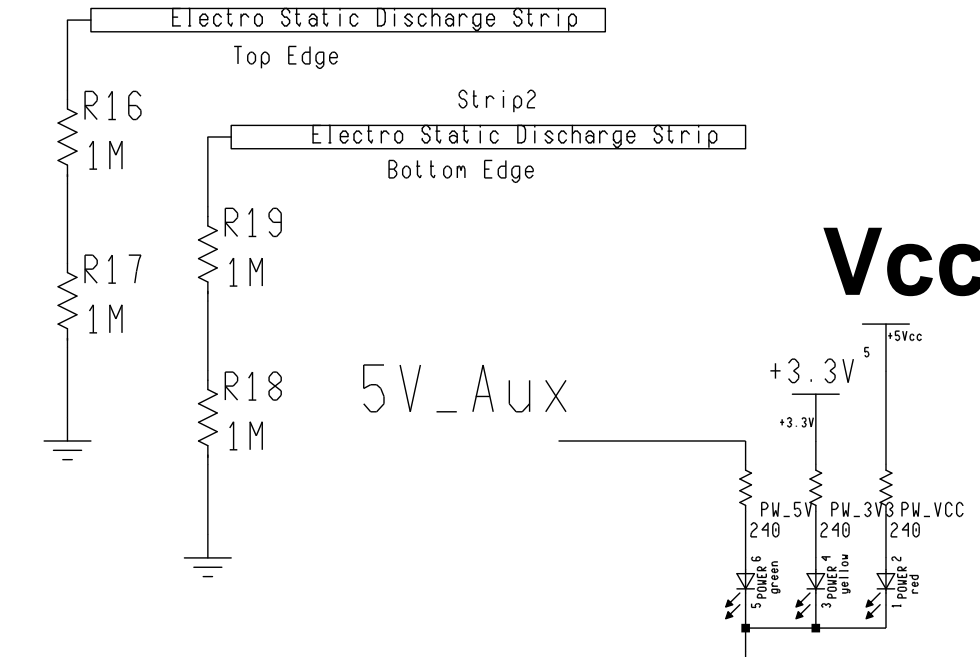
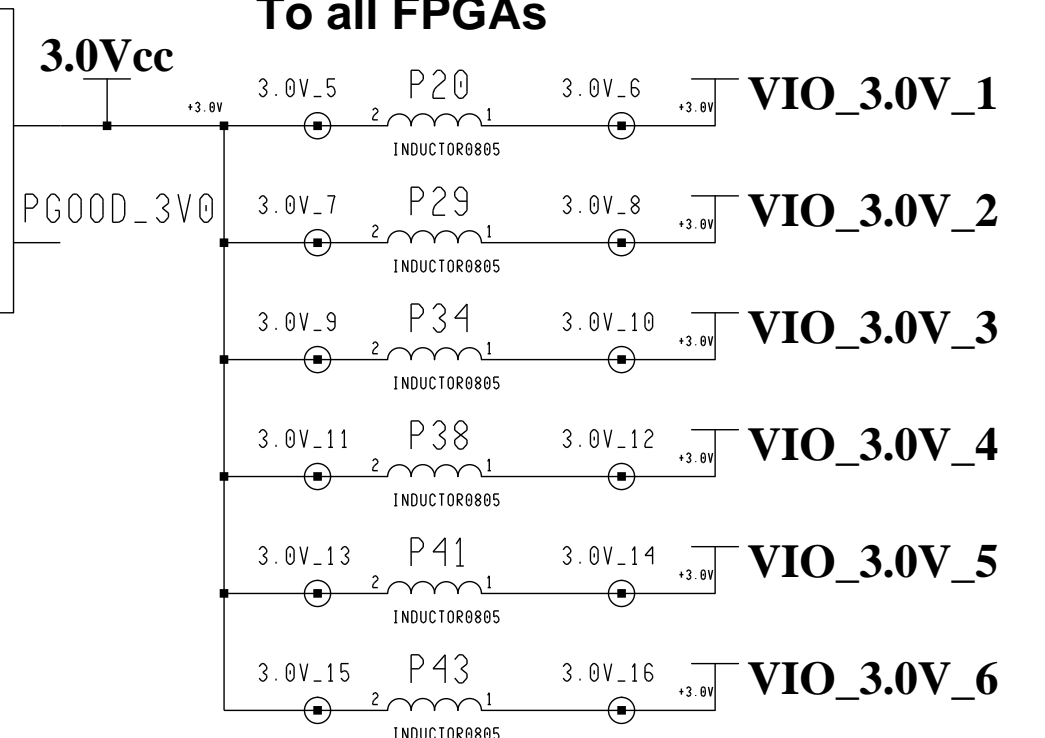

**Sheet 10-3
Power 2x12A**

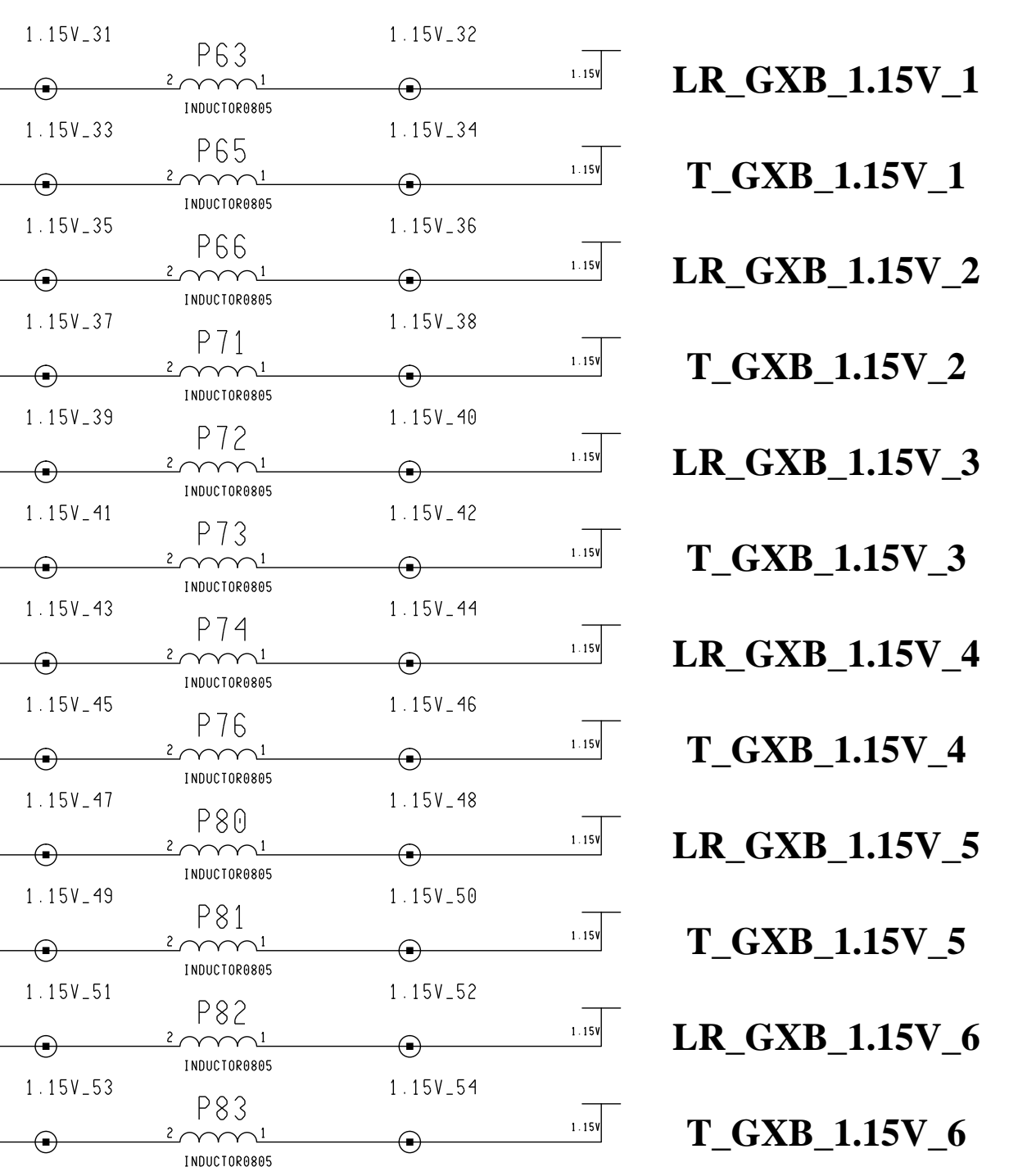
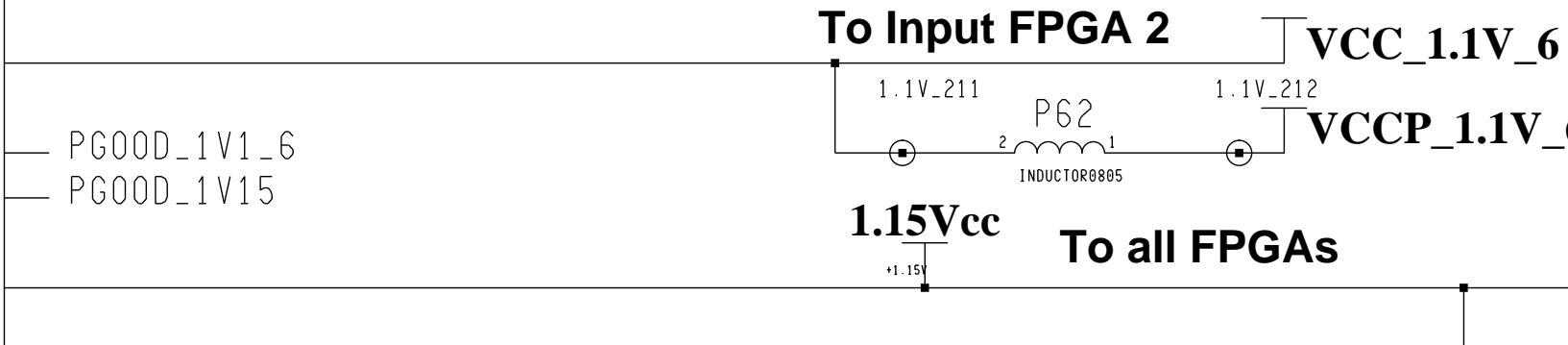

**Sheet 10-2
Power 2x12A**

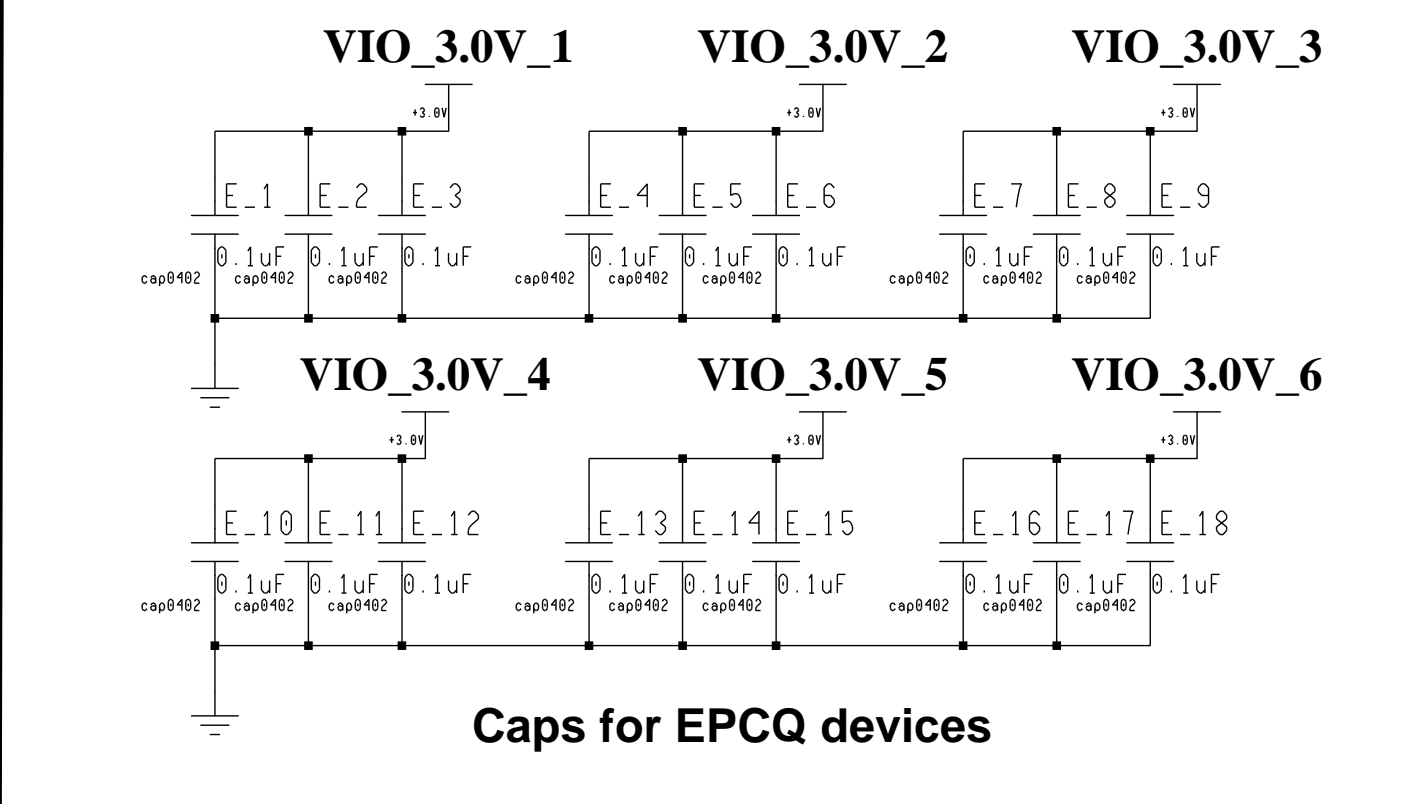
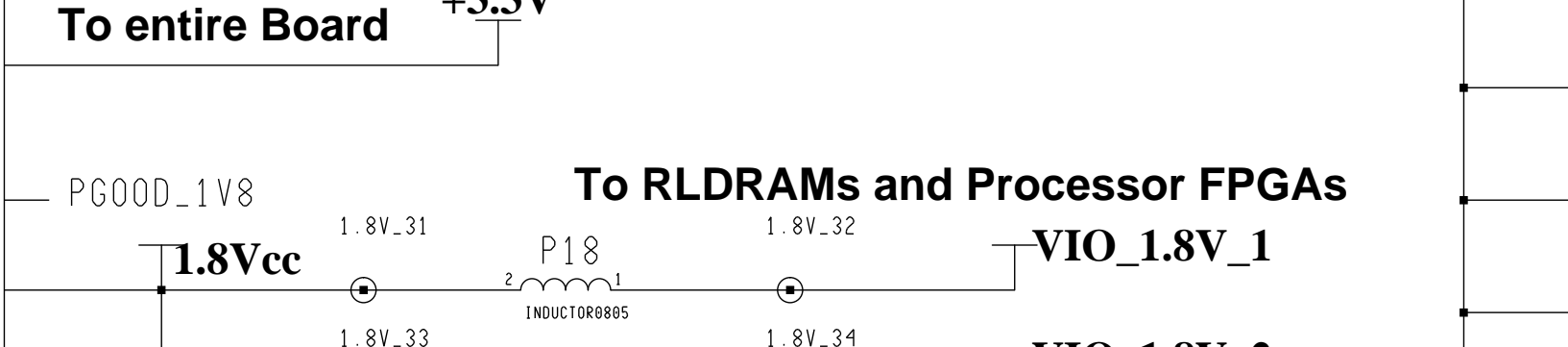

Engineer	M.Bogdan	The University of Chicago 5640 S. Ellis Ave. Chicago, IL 60637	
Drawn by	M.Bogdan		
R&D CHK		TITLE	Size
DATE:	3/14/14	Power Supplies FTK-AM-AUX Card	
TIME:	11:17 am		
REV	B	DRW.	2808
		Sheet	8